



PACIFIC HALIBUT MARKET PROFILE

PREPARED BY: IPHC SECRETARIAT (B. HUTNICZAK; 4 & 13 JANUARY 2022)

PURPOSE

The purpose of this document is to provide stakeholders with general information about the Pacific halibut markets and the formation of the price paid for Pacific halibut products by final consumers (end-users). The content of this analysis serves as a base for understanding Pacific halibut's contribution to the Gross Domestic Product (GDP) along the entire value chain, *from the hook-to-plate*.

INTRODUCTION

Canada and the United States of America account for the majority (70-80% over the 2014-2019 period, **Table 1**) of Pacific halibut global output, as reported by the Food and Agriculture Organization of the United Nations (FAO, 2021b). The aquaculture output of Pacific halibut is currently marginal (not specified by the FAO (2021a)), but on the rise (Welch, 2020a). In Canada's and the United States' Pacific Northwest (including Alaska), Pacific halibut accounts for about 5% of fish production (harvest) value, while in terms of volume, less than 0.5% (based on 2019 data, AKFIN, 2021; DFO, 2021; PacFIN, 2021). This showcases its high unit value (typically over USD 5/lb, see also **Figure 1**) in comparison with other fisheries in the Pacific Northwest region.

Pacific halibut is a premium product known for its mild taste and flaky texture, suitable for a variety of dishes and flavor combinations. It is commonly grilled, fried, baked, sautéed, and poached. As it has relatively few bones, it makes for a popular food fish. It is primarily sold to upscale retail outlets and white-tablecloth restaurants, resulting in high price markups in the supply chain. Amidst the pandemic, Pacific halibut products also noted an increase in online sales, following the general trend for more seafood products consumption at home (Wells, 2020), but since then the restaurant industry started showing a strong recovery (Kelso, 2021).

Pacific halibut is typically consumed as fillets, but it is also sold as fletches,¹ steaks, collars, or cheeks. Cheeks are considered a high-valued delicacy. Fresh products are available during the Pacific halibut commercial fishing season, starting typically sometime in March and ending in November or December.² Frozen products can be found year-

¹ Fletch is a skinless fillet cut for large flatfish, such as Pacific halibut. The fletch is then further divided into boneless portions.

² Until 2019, the fishing season end date was set for November. In 2020, an extended commercial fishing season in Canada was agreed upon because of unusual circumstances (Covid-19 pandemic), and the extension allowed fishing

round. Excess fish parts are ground and discharged as waste or turned into fish meal (AFSC, 2019).

The majority of Pacific halibut on the North American market is produced from fish landed in Alaska or British Columbia, and processed in Canada or the United States, but wholesalers carry also Pacific halibut products originating from Russian waters processed in China. These are typically offered in the form of fletches (Tradex, 2021c).

The main substitute product is Atlantic halibut, but weak substitutes include Pacific cod and other whitefish (AFSC, 2019).

Table 1: Global Pacific halibut production (t, round weight, 2014-2020).

	2014	2015	2016	2017	2018	2019	2020 ⁽¹⁾
Canada	3,619	3,710	3,747	3,812	3,330	3,163	2,959
USA	10,479	11,008	11,286	11,895	9,877	11,203	10,106
Russia	4,754	4,220	4,346	3,895	5,932	4,172	NA
% IPHC	74.8%	77.7%	77.6%	80.1%	69.0%	77.5%	NA

⁽¹⁾ Based on IPHC data. Note that the FAO data in principle should include harvest volume for all commercial, industrial, recreational, and subsistence purposes, and aquaculture. However, the FAO values for Canada and USA align with commercial landings reported by DFO (2021) and NOAA (2021a).

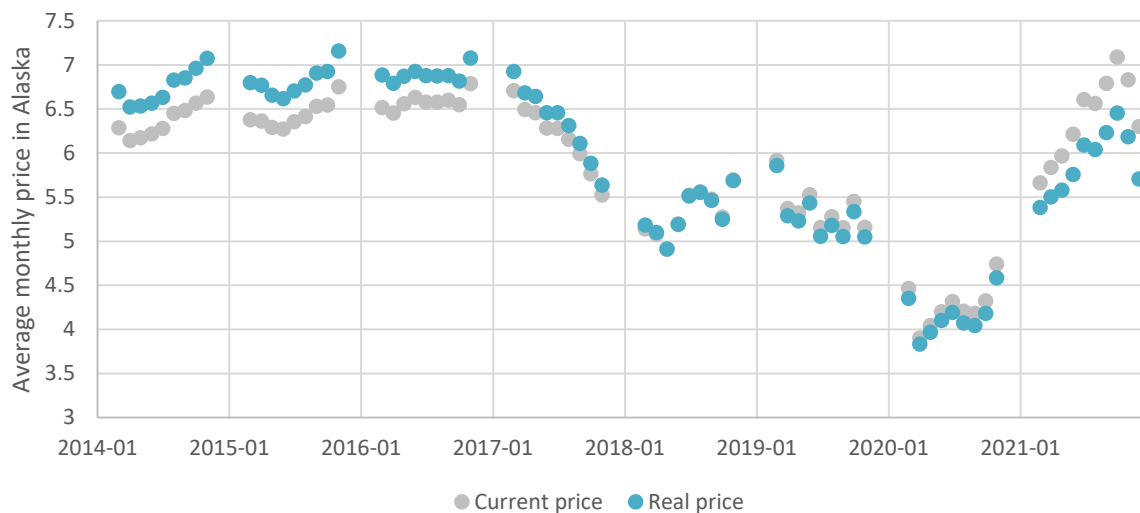

Notes: Based on eLandings data (ADFG, 2021). Converted from nominal to real prices using Consumer Price Index (CPI, BLS 2021), with baseline in January 2019.

Figure 1: Average monthly Pacific halibut ex-vessel price in Alaska.

in the IPHC Regulatory Area 2B up to December 7 (regulatory update from 17 September 2020). Current (2021) regulations provide for the fishing season lasting until December 7 in all IPHC Regulatory Areas (latest update from 22 February 2021).

PROCESSING AND PRIMARY WHOLESALE

The total value of Pacific halibut products processed by Alaska and British Columbia (i.e., wholesale value)³ in 2019 was about USD 165.3 mil., of which Alaska accounted for 66%.⁴ The covid-19 pandemic had a considerable impact on the 2020 output of the processing sector in Alaska. The state noted a 28% year-on-year drop in wholesale value, from USD 108.6 mil. in 2019 to USD 78.3 mil in 2020. However, the 2021 season was marked by a prompt recovery, with wholesale prices continuing an upward trend throughout the year (Tradex, 2021a). British Columbia noted a less pronounced Pacific halibut wholesale value drop between 2019 and 2020, about 10%, from USD 53.8 mil. to USD 48.2 mil. Early indicators for 2021 based on monthly data on sales by the *Seafood product preparation and packaging* sector in British Columbia (Statistics Canada, 2021b; data available for July-October) suggest a recovery in earlier months (year-on-year increase in July and August, data for January-June suppressed to meet the confidentiality requirements) but overall further decrease in sales by 11%.

The main Pacific halibut product of both Alaska and British Columbia is headed and gutted (H&G) fish. It accounted for 65% of 2019 Alaska production. Fresh products dominate British Columbia's production, while Alaska delivers a mix of fresh and frozen products (fresh products typically account for 50-60% of output value). **Figure 2** and **Figure 3** show year-to-year changes in Pacific halibut processing output by type of product (fresh, frozen, other, for Alaska only), and wholesale value in comparison with landings value (values in 2020 USD).

H&G fish are typically available as individually quick frozen (IQF) product, most commonly 60-80lb in size.⁵ H&G fish marketed in North America are typically produced by national processors from Alaska and British Columbia's harvest. The second most popular product at the wholesale level is Pacific halibut IQF fletches (typically 1-3lb in size). The origin of

³ This excludes commercial production in Washington, Oregon, and California (collectively, WOC). See details on gaps in economic statistics for the Pacific halibut processing sector described in [IPHC-2021-ECON-02](#). The estimated output of the US West Coast is USD 5.0 mil. The estimate is based on the Pacific halibut multiregional economic impact assessment (PHMEIA) model (see details in [IPHC-2022-AM098-INF04](#)).

⁴ The sum is based on values reported by the Alaska Department of Fish and Game (COAR, 2021) and the Province of BC (as reported to the IPHC, see [IPHC-2021-AM097-NR01](#) or [IPHC-2022-AM098-NR01](#)). In the case of British Columbia, the wholesale value may include the value of imported seafood. This is not the case for Alaska, particularly not for the last number of years. As noted by the ADFG, there may be a handful of records pertaining to such scenario, but these are not recent (Sabrina Larsen, ADFG, personal communication). The Secretariat also discussed with the Province of BC the possibility of splitting locally sourced production and processing of imports, but no estimates related to product origin are currently available.

⁵ Wholesale market analysis beyond statistics published by national agencies is based on the historical prices for offers made via Tradex Live (Tradex, 2021c). Tradex Foods is sourcing, processing, distributing and marketing frozen seafood supplying over 40 mil. lbs per year to food service, supermarkets, and retailers worldwide. Tradex is based in Canada and has offices in Victoria and Vancouver. The sample size for Pacific halibut products for 2018 was 153, for 2019 72, for 2020 34, and for 2021, to date, 13. Pacific halibut products are typically offered as Free on Board (FOB) Seattle, FOB Vancouver, or FOB Bellingham. FOB refers to a trade agreement in which the seller is responsible for clearing goods for export, delivering them to the vessel, and loading them for transport at the named port of departure.

the fletches, unlike the H&G fish, varies. What is available on the market is typically a mix of USA-produced fish originating from Alaskan waters and China-produced fish (typically 20-30% of offers on fletches, besides for 2020), much of which is produced from fish harvested in Russian waters. Harvest from Russia is typically about 10-35% cheaper (Table 2).

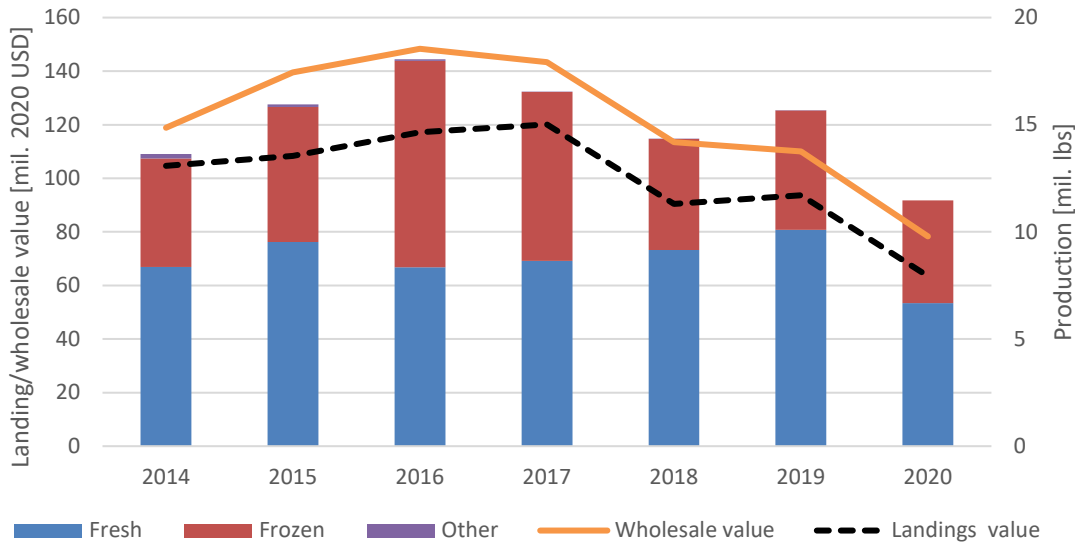

Based on data submitted through Commercial Operator's Annual Report (COAR, 2021).

Figure 2: Pacific halibut production – Alaska (2014-2020).

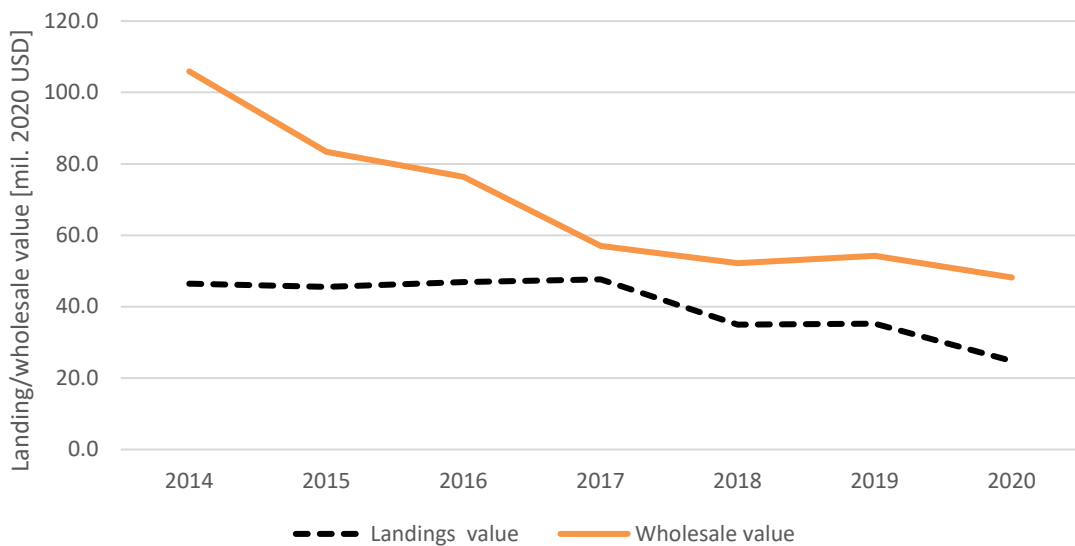

Based on data provided by the Province of BC (Ministry of Agriculture). Output by type of product not available.

Figure 3: Pacific halibut production - British Columbia (2014-2020).

Table 2: Pacific halibut prices on the wholesale market – comparison between Alaskan and Russian harvest (Tradex, 2021b).

	Fishing Area	2020	2019
Pacific halibut fletches, USA production, 1-3lb, 3-5lb	Alaska	USD 10.25-12.75/lb	USD 13.25-14.50/lb
Pacific halibut fletches, China production, 1-3lb, 3-5lb	Russia	USD 9.25-10.75/lb	USD 8.50-10.50/lb
Pacific halibut H&G, USA production, 10-20lb, 20-40lb	Alaska	USD 6.35-6.65/lb	USD 6.50-7.90/lb
Pacific halibut H&G, Russia production, 10-20lb, 20-40lb	Russia	USD 5.80/lb	USD 5.80/lb

RETAIL MARKET AND SERVICES

On the retail market, Pacific halibut is most commonly sold in the form of fillets (portions, 4-8oz each), but one can also find Pacific halibut steaks and halibut cheeks. Some retailers (e.g., Pike Place Fish Market in Seattle) also sell fish whole. In 2021, fresh Alaskan Pacific halibut fillets routinely sold for USD 24-28 a pound (Welch, 2021), and often more, downtown Seattle (e.g., USD 38 at Pike Place Market). Online, Pacific halibut fillets retailed in late 2021 at about USD 35-48 per pound for fillet portions and USD 35-36 per pound for steaks. Cheeks were available at USD 34-47 per pound.⁶ Online, the shoppers can also choose between Pacific halibut and Atlantic halibut. Atlantic halibut typically retails at slightly lower prices. One online retailer also carried aquaculture-produced halibut from Norway at USD 30 per pound.⁷

Pacific halibut dishes at the restaurants in metropolitan areas typically sell for USD 37-43 for a dish including a 6oz fish portion.⁸ This translates to about USD 100-115 per pound.

Pacific halibut retail market and COVID-19

Widespread closure of restaurants (**Figure 4**),⁹ the Pacific halibut's biggest customers, diminished the demand for fish, particularly high-quality fresh fish that fetch higher prices. Lower prices, down in 2020 by up to 30% in comparison with the previous year (Stremple, 2020), also seen in data from fish tickets from the eLandings reporting system, ADFG,

⁶ The analysis is based on the database created specifically to analyze retail prices of Pacific halibut. The database currently includes 21 retailers carrying Pacific halibut. It covers all places mentioned in the USA today as the best places to order seafood online (Birdsall, 2020), as well as major retailers that advertise Pacific halibut as a product available on Instacart (i.e., prices could be verified via www.instacart.com). The database includes only products that are specifically advertised as Pacific halibut, i.e., excludes products when halibut species was not specified. The database also records the fishing area.

⁷ Norway is increasing aquaculture production of Atlantic halibut for export, including production of sashimi-grade halibut (Wright, 2018).

⁸ Based on prices in 26 seafood restaurants in major metropolitan areas in Alaska, Washington, and Oregon (Anchorage, Seattle, Bellingham, Portland) that publish menus online (dinner offerings).

⁹ Equivalent data for Canada is published by Statistics Canada annually and is currently available up to 2019 (Table 11-10-0125-01, Statistics Canada 2021). Thus, at this time, similar effects cannot be confirmed for Canada.

2021), caused a slow first half of the 2020 season (Ess 2020, IPHC, 2021). However, amidst the pandemic, Pacific halibut products also noted an increase in online sales, following the general trend for more seafood products consumption at home (Wells, 2020). At the beginning of the lockdown in spring 2020, halibut was the top 5th surging cooking recipe searched online in the Seattle-Tacoma metro area (Varriano, 2020). By spring 2021, the restaurant industry started showing a strong recovery (Kelso, 2021), pushing up the prices of Pacific halibut.

Less harvest activity in 2020 had repercussions in the economy beyond the harvest sector as it also affected harvest sector suppliers and downstream industries that rely on its output. Outbreaks of covid-19 in fish processing plants (Estus, 2020; Krakow, 2020) affected economic activity generated regionally by this directly related to the Pacific halibut supply sector. Moreover, seafood processors incurred additional costs related to protective gear, testing, and quarantine accommodations (Ross, 2020; Sapin & Fiorillo, 2020; Welch, 2020b), and these costs were passed on to consumers.

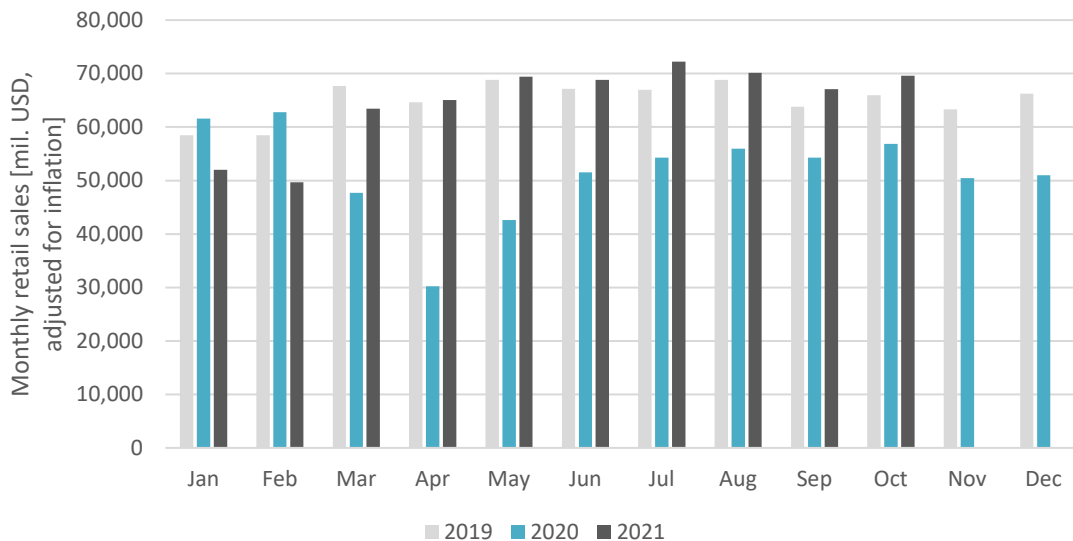

Converted from nominal to real values using Consumer Price Index (CPI, BLS 2021), with baseline in January 2020.

Figure 4: *Monthly Retail Trade and Food Services - Food Services and Drinking Places: U.S. Total* (US Census, 2021).

Certification of Pacific halibut products

Pacific halibut longline fishery in the Bering Sea off Alaska, and the Pacific waters off British Columbia and Washington state are certified by the [Marine Stewardship Council](#) (MSC). Sustainable production certification, such as the one offered by the MSC, typically adds about 15%, and up to 30% depending on fishery, premium to the product price (Asche & Bronnmann, 2017; Blomquist et al., 2019; Roheim et al., 2011; Vitale et al., 2020).

The USA MSC catch certification requires product landing at a processor listed on the certificate.¹⁰ The BC catch is certified via the Pacific Halibut Management Association of BC (PHMA). Access to the certificate for Canada Pacific halibut is limited to approved fish buyers in good standing with PHMA.¹¹

Pacific halibut Alaska catch is also certified through the [Responsible Fisheries Management \(RFM\) certification program](#), which is aligned with the FAO Code of Conduct for Responsible Fisheries. RFM certificate also covers Pacific halibut delivered by Southeast Alaska salmon trollers.

Western Bering Sea Pacific halibut longline fishery in Russian territorial waters operated by Longline Fishery Association (57 vessels in total) is also certified by the MSC ([MSC-F-31439](#)). This fishery is primarily processing fish on board and landing in the ports of Vladivostok or Petropavlovsk-Kamchatskyis.

Traceability

The ability to fully trace a product from the point of sale back to its point of origin, assuring fish is sustainably and legally caught, is increasingly important to customers, although it is mostly adopted in the relation to products that may be illegally sourced (e.g., use of blockchain for strengthening tuna traceability to combat illegal fishing, Visser & Hanich, 2018).

All Pacific halibut in Canada, including Canadian-caught Pacific halibut landed in the United States, are tagged by an observer and certified by Fisheries and Oceans Canada at the point of initial offloading. Each tag has a unique serial number that can be used to trace the fish back to its point of landing.

No widely-practiced traceability initiatives were identified for the USA-caught Pacific halibut. However, some online retailers offer products linked to specific harvesters in Alaska.¹²

SEAFOOD TRADE

Understanding the Pacific halibut trade balance is vital to assessing the total supply of Pacific halibut products available on the market. Export of the raw products eliminates it from the country's value chain, preventing additional value added contribution. Imports

¹⁰ There are 35 companies approved to participate in the use of MSC Certification for Alaska and Washington state Pacific halibut ([MSC-F-31514](#))

¹¹ Currently, there are 13 authorized fish buyers named in the Certificate ([MSC-F-30019](#)).

¹² For example, Crowd Cow advertises Pacific halibut from a specific fisher in the Prince William Sound. See details at <https://www.crowdcow.com/products/wild-alaskan-halibut>.

compete with other domestically-produced seafood, but can create additional economic impact when there are associated markups.

NOAA database (NOAA, 2021b) provides no evidence for the export of fresh Pacific halibut, although some must be included in the generic category HS¹³ 0302290100: *Flatfish NSPF fresh*. There is a modest import by Canada¹⁴ of fresh halibut (HS 0302210090: *Halibut NES fresh/chilled*) from Alaska (USD 11.9 mil. in 2019, USD 9.5 mil. in 2020), and Washington and Oregon (USD 7.3 mil. in 2019, USD 3.7 mil. in 2020), presumably dominated by Pacific halibut. Frozen Pacific halibut exports from the United States are lumped with Atlantic halibut (HS 303310015: *Flatfish halibut Atlantic, Pacific frozen*). Within this category, exports from Alaska and WOC were USD 4.6 mil. in 2019 and USD 4.1 mil. in 2020. Comparing this with Canadian statistics suggests that the majority of frozen Pacific halibut is sent to the Canadian market (USD 4.3 mil. in 2019 and USD 4.0 mil. in 2020, HS 0303310020: *Halibut, Pacific, frozen*). Overall, this suggests that the majority of the US-caught Pacific halibut is contributing to the US economy throughout its value chain. Exports of processed Pacific halibut products (e.g., fillets) are difficult to trace because they are generally merged with other halibut species and could include imported products.

Imports of fresh Pacific halibut, primarily coming from Canada (USD 29.5 mil. with 89% from Canada in 2019; USD 23.1 mil. with 89% from Canada in 2020), adds to the US domestic supply. There is, however, strong evidence that the domestic Pacific halibut is facing increasing pressure from imports. While the imports of fresh products (HS 302210020: *Flatfish Halibut Pacific Fresh*) increased between 2018 and 2019 only modestly (6%), import of frozen Pacific halibut (HS 0303310020: *Flatfish Halibut Pacific Frozen*) increased by 165%. The majority of the increase is attributed to imports from Russia. Although the import of frozen Pacific halibut is still modest (USD 7.5 mil. in 2019), and decreased in 2020 (to USD 5.9 mil.), there are growing concerns regarding the Alaskan Pacific halibut sector's vitality given the competition flooding the market with cheaper products (Welch, 2020a).

Fresh Pacific halibut accounts for about 5% of fresh fish exports from British Columbia, amounting to USD 26.1 mil. in 2019 (USD 20.8 mil. in 2020). Canadian statistics on exports of frozen Pacific halibut (HS 03033120: *Pacific halibut, frozen*) end in 2016, but replacing it generic frozen halibut category (HS 03033100: *Halibut frozen*) suggest that British Columbia exported in 2019 also up to USD 0.6 mil. worth of frozen Pacific halibut products. This export category noted also an increase in 2020 to USD 1.4 mil. There are no fresh Pacific halibut-specific import statistics for Canada. Fresh Pacific halibut is lumped in HS 0302210090: *Halibut NES fresh/chilled*, but data on import from Alaska and

¹³ The Harmonized System (HS) is a standardized numerical method of classifying traded products.

¹⁴ Trade statistics provided directly by the Agriservice BC (Province of British Columbia), personal communication.

WOC suggest import by British Columbia of USD 6.1 mil. in 2019 and USD 4.1 mil. in 2020, and by Canada as a whole of USD 19.2 mil. in 2019 and USD 13.2 mil. in 2020. Imports of frozen Pacific halibut fillets (HS 0304830020: *Fillets, of Pacific halibut, frozen*) by Canada amounted to USD 11.0 mil. in 2019, of which USD 9.0 mil. (81%) was from China, and USD 7.4 mil. in 2020, of which USD 6.0 mil. (82%) from China.

FINAL REMARKS

Figure 5 summarizes market flows for Pacific halibut, from the landing area to retail and services, accounting for trade balance in fresh, frozen, and processed products, when these could be attributed to Pacific halibut specifically.¹⁵ Overall, it is estimated that the total value added activity related to Pacific halibut products added up to USD 230 mil. in the United States and USD 140 mil. in Canada. The total consumer expenditures on Pacific halibut products in the United States are assessed at USD 460 mil, and in Canada at USD 232 mil. **Table 3** in **Appendix I** summarizes calculations of the value added, margins, and consumer expenditures for commercial Pacific halibut fishery products in Canada and the United States in 2019.

Understanding the formation of the price paid by final consumers (end-users) is an important step in assessing the contribution of Pacific halibut to the GDP along the entire value chain. However, it is important to note that there are many seafood substitutes available to buyers. Thus, including economic impacts beyond processors and wholesalers in the economic impact assessment (i.e., PHMEIA model, see details in [IPHC-2022-AM098-INF04](#)), as opposed to assessing the snapshot contribution to the GDP along its entire value chain, would be misleading when considering that it is unlikely that supply shortage would result in a noticeable change in retail or services level gross revenues (Steinback & Thunberg, 2006).

¹⁵ As noted in section Seafood trade, processed Pacific halibut products (e.g., fillets) are often difficult to trace because they are generally merged with other halibut species and could include imported products.

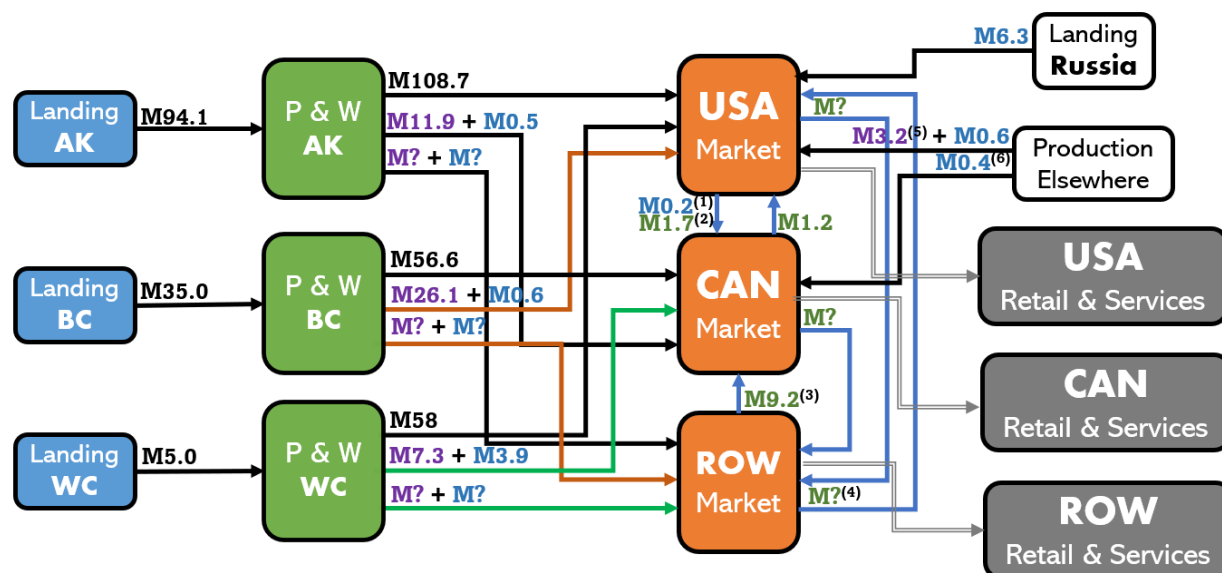

Notes: All values associated with arrows are based on 2019 data, all in millions USD. P&W stands for processing and wholesale. This includes seafood products preparation and packaging, i.e., the output can be fresh fish. ROW stands for the rest of the world, i.e., all countries besides Canada and the United States. Values in black indicate domestic production. Values in color inform on trade: purple – fresh fish, blue – frozen fish, and green – processed products (here: fillets). ⁽¹⁾ Imports of frozen products from states other than AK, WA, OR, or CA. ⁽²⁾ See footnote 18. ⁽³⁾ Of which USD 9.0 mil. coming from China. ⁽⁴⁾ Excludes processed products because it is reported without the distinction between halibut species. However, fletches produced from Russian harvest processed in China are available on the market (Tradex, 2021c). ⁽⁵⁾ USD 2.5 mil. reported as imported from Mexico. ⁽⁶⁾ Of which USD 0.3 mil. coming from South Korea.

Figure 5: Market flows for Pacific halibut.

REFERENCES

- ADFG. (2021). *Commercial Fishing Reporting: eLandings*. <http://www.adfg.alaska.gov/index.cfm?adfg=fishlicense.elandings>
- AFSC. (2019). Wholesale Market Profiles for Alaska Groundfish and Crab Fisheries. In *Alaska Fisheries Science Center*. <http://www.mcdowellgroup.net/wp-content/uploads/2020/09/wholesale-market-profiles-for-alaska-groundfish-and-crab-fisheries-noaa.pdf>
- AKFIN. (2021). *Alaska Fisheries Information Network (AKFIN) APEX reporting system*. Alaska Fisheries Information Network. <https://reports.psmfc.org/akfin>
- Asche, F., & Bronnmann, J. (2017). Price premiums for ecolabelled seafood: MSC certification in Germany. *Australian Journal of Agricultural and Resource Economics*, 61(4), 576–589. <https://doi.org/10.1111/1467-8489.12217>
- Birdsall, L. (2020). The 10 best places to order seafood online. *USA Today*. <https://www.usatoday.com/story/tech/reviewedcom/2020/08/11/10-best-places-order-seafood-online/3348908001/>

- Blomquist, J., Bartolino, V., & Waldo, S. (2019). Price premiums for eco-labelled seafood: effects of the MSC certification suspension in the Baltic Sea cod fishery. *European Review of Agricultural Economics*, 47(1), 50–70. <https://doi.org/10.1093/erae/jby047>
- BLS. (2021). *CPI for All Urban Consumers (CPI-U)*. US Bureau of Labor Statistics. <https://data.bls.gov/cgi-bin/surveymost>
- COAR. (2021). *Commercial Fishing Reporting*. Commercial Operator's Annual Reports. <https://www.adfg.alaska.gov/index.cfm?adfg=fishlicense.coar>
- DFO. (2021). *Seafisheries Landings*. Fisheries and Oceans Canada. <https://www.dfo-mpo.gc.ca/stats/commercial/sea-maritimes-eng.htm>
- Ess, C. (2020). Restaurant closings, depressed Japan market push halibut, blackcod prices down. *National Fisherman*. <https://www.nationalfisherman.com/alaska/restaurant-closings-depressed-japan-market-push-halibut-blackcod-prices-down>
- Estus, J. (2020). COVID spikes at Alaska fish processing plants raise alarm. *Indian Country Today*. <https://indiancountrytoday.com/news/covid-spikes-at-alaska-fish-processing-plants-raise-alarm>
- FAO. (2021a). *Global Aquaculture Production*. Food and Agriculture Organization. <http://www.fao.org/fishery/statistics/global-aquaculture-production/query/en>
- FAO. (2021b). *Global Capture Production*. Food and Agriculture Organization. <https://www.fao.org/fishery/statistics/global-capture-production/en>
- IPHC. (2021). *Percentage of Directed Commercial Pacific halibut fishery limit landed by week of year*. <https://www.iphc.int/data/year-to-date-directed-commercial-landing-patterns-ak-and-bc>
- Kelso, A. (2021). Restaurant Industry Showing Strong Recovery , But Sales Remain Down By \$ 110 Billion From Pre-Pandemic Projections. *Forbes*. Restaurant Industry Showing Strong Recovery , But Sales Remain Down By \$ 110 Billion From Pre-Pandemic Projection
- Krakow, M. (2020). 56 workers at Anchorage seafood plant test positive for COVID-19. *Anchorage Daily News*. <https://www.adn.com/alaska-news/anchorage/2020/07/24/56-workers-at-anchorage-seafood-processing-plant-test-positive-for-covid-19/>
- NMFS. (2018). *Fisheries of the United States 2017*. <https://www.fisheries.noaa.gov/national/fisheries-united-states-2017>
- NOAA. (2021a). *Annual commercial landing statistics*. <https://foss.nmfs.noaa.gov/apexfoss/f?p=215>
- NOAA. (2021b). *Foreign Trade*. NOAA Fisheries. <https://www.st.nmfs.noaa.gov/apex/f?p=213:3>
- PacFIN. (2021). *Pacific Fisheries Information Network (PacFIN) APEX reporting system*.

- Pacific Fisheries Information Network. <https://reports.psmfc.org/pacfin>
- Roheim, C. A., Asche, F., & Santos, J. I. (2011). The Elusive Price Premium for Ecolabelled Products: Evidence from Seafood in the UK Market. *Journal of Agricultural Economics*, 62(3), 655–668. <https://doi.org/https://doi.org/10.1111/j.1477-9552.2011.00299.x>
- Ross, I. (2020). *For Alaska's seafood processors, the COVID-19 pandemic has cost tens of millions of dollars*. KDLG. <https://www.kdlg.org/post/alaskas-seafood-processors-covid-19-pandemic-has-cost-tens-millions-dollars>
- Sapin, R., & Fiorillo, J. (2020). Seafood processors pay a steep price to keep workers safe from coronavirus. *IntraFish*. <https://www.intrafish.com/processing/seafood-processors-pay-a-steep-price-to-keep-workers-safe-from-coronavirus/2-1-852502>
- Statistics Canada. (2021a). *Table 11-10-0125-01 Detailed food spending, Canada, regions and provinces*. <https://doi.org/10.25318/1110012501-eng>
- Statistics Canada. (2021b). *Table 16-10-0048-01 Manufacturing sales by industry and province, monthly*. <https://doi.org/10.25318/1610004801-eng>
- Steinback, S. R., & Thunberg, E. M. (2006). Northeast Region Commercial Fishing Input-Output Model. *NOAA Technical Memorandum NMFS-NE, 188*.
- Stremple, C. (2020). Local fish put Haines residents to work despite COVID-19 economic slump. *KHNS*. <https://khns.org/local-fish-put-haines-residents-to-work-despite-covid-19-economic-slump>
- Tradex. (2021a). *Halibut Inventories Fall Short Despite Strong Market*. 3-Minute Market Insight. <http://www.tradexfoods.com/3mmi/2021/09-13-halibut-inventories-fall-short-despite-strong-market>
- Tradex. (2021b). *Pacific Halibut Update: 2021 Fishery Limit, a 2020 Season through a Pandemic, Stabilized Pricing and Increased Demand*.
- Tradex. (2021c). *Tradex Live: Historical prices*. <http://live.tradexfoods.com/historical-prices.php>
- US Census. (2021). *Monthly Retail Trade and Food Services*. <https://www.census.gov/econ/currentdata/>
- Varriano, J. (2020). Everyone's been cooking like crazy during the coronavirus stay-home order. Here's what Seattle's been making. *The Seattle Times*. <https://www.seattletimes.com/life/food-drink/everyones-been-cooking-like-crazy-during-the-coronavirus-stay-home-order-heres-what-seattles-been-making/>
- Visser, C., & Hanich, Q. A. (2018). How blockchain is strengthening tuna traceability to combat illegal fishing. *The Conversation*, 1–4. <https://theconversation.com/how-blockchain-is-strengthening-tuna-traceability-to-combat-illegal-fishing-89965>
- Vitale, S., Biondo, F., Giosuè, C., Bono, G., Okpala, C. O. R., Piazza, I., Sprovieri, M., & Pipitone, V. (2020). Consumers' perception and willingness to pay for eco-labeled

seafood in Italian hypermarkets. *Sustainability*, 12, 1–13.
<https://doi.org/10.3390/su12041434>

Welch, L. (2020a). Alaska Halibut Gets Battered by Foreign Import. *Fish Factor*.
<https://www.adn.com/business-economy/2020/05/12/alaska-halibut-gets-battered-by-foreign-imports-including-a-new-russian-fishery/>

Welch, L. (2020b). Alaska Seafood Processors Get Clobbered by COVID Costs. *Alaska Fish Radio*.
<https://www.seafoodnews.com/Story/1179409/Alaska-Seafood-Processors-Get-Clobbered-by-COVID-Costs>

Welch, L. (2021). Halibut prices to AK fishermen remain high along with customer demand. *Alaska Fish Radio*.
<http://www.alaskafishradio.com/halibut-prices-to-ak-fishermen-remain-high-along-with-customer-demand/>

Wells, P. (2020). A Quarantine Silver Lining for Seafood. *The New York Times*.
<https://www.nytimes.com/2020/05/05/dining/seafood-fish-coronavirus.html>

Wright, J. (2018). Norway showcases halibut farm as sustainability star. *Responsible Seafood Advocate*.
<https://www.globalseafood.org/advocate/norway-showcases-halibut-farm-as-sustainability-star/>



Appendix I

Table 3: Summary of 2019 value added, margins, and consumer expenditures for commercial Pacific halibut fishery products in Canada and the United States.

Sector or type of activity	Purchase of fishery inputs	Mark-up of fishery inputs	Total mark-up within sector	Value added as a percent of total mark-up	Value added within sector	Value of sales by sector	Value added contribution	Exported fishery products ¹⁶	Source
	[mil. USD]	Percentage of fishery inputs	[mil. USD]	Percentage	[mil. USD]	[mil. USD]	Percentage of GDP contribution	[mil. USD]	
USA									
Domestic harvest									
AK	-	100%	94.1	27.9%	26.3	94.1	11.4%	-	AKFIN (2021)
WA, OR, CA (WOC)	-	100%	5.0	40.4%	2.0	5.0	0.9%	-	PacFIN (2021)
Processing/wholesale									
AK	92.5	17.5%	16.2	17.4%	2.8	108.7	1.2%	-	COAR (2021)
WA, OR, CA (WOC)	5.0	14.8%	0.7	37.1%	0.3	5.8	0.1%	-	Markup based on communication with NOAA (Jerry Leonard, NOAA NWFSC)
Rest of the USA	~0	n.a.	n.a.	n.a.	~0	~0	~0%	-	No indication of processing outside AK/WOC
Imports, fresh	29.5	-	-	-	-	29.45	-	-	NOAA (2021b) ¹⁷
Exports, fresh	-	-	-	-	-	-	-	19.2	AgriService BC ¹⁸
Import, frozen	7.5	-	-	-	-	7.45	-	-	NOAA (2021b) ¹⁹
Export, frozen	-	-	-	-	-	-	-	4.3	AgriService BC ²⁰

¹⁶ This could also include harvest landed in foreign ports, but this does not apply to Pacific halibut.

¹⁷ Includes HS 0302210020: *Flatfish halibut Pacific fresh*. Canada accounts for the majority (89% in 2019) of this import.

¹⁸ Pacific halibut may be included in NOAA's database (NOAA, 2021b) under HS 0302290100: *Flatfish NSPF fresh*. Canadian statistics specify the import of fresh halibut (HS 0302210090: *Halibut NES fresh/chilled*) from Alaska, Washington, and Oregon. Here, we assume that fresh halibut from these regions is most likely Pacific halibut.

¹⁹ Includes HS 0303310020: *Flatfish halibut Pacific frozen*. The majority of this production (84% in 2019) is coming from Russia but minor import is also recorded from China and South Korea. Canada accounts for a small portion (3% in 2019) of this import.

²⁰ NOAA's database (NOAA, 2021b) lumps exports of frozen Pacific halibut with frozen Atlantic halibut (HS 0303310015: *Flatfish halibut Atlantic Pacific frozen*). As the majority of this category is reported as destined for Canada, we use here HS 0303310020: *Halibut Pacific frozen* imports to Canada from Alaska, Washington, Oregon, and California.

Imports, processed	1.2	-	-	-	-	1.2	-	-	NOAA (2021b) ²¹
Exports, processed	-	-	-	-	-	-	-	2.1	NOAA (2021b) ²²
Secondary processing	127.0	63%	80.0	28%	22.4	207.0	9.8%		FUS ²³
Retail									
Food service	124.2	182%	226.0	70%	158.2	350.19	68.9%	-	FUS
Stores	82.8	33%	27.3	64%	17.5	110.11	7.6%	-	FUS
TOTAL VALUE ADDED ACTIVITY					229.5		100%		
CONSUMER EXPENDITURES						460.3			
Canada									
Domestic harvest									
BC	-	100%	35.0 [CAD 46.4]	88.9	31.1	35.0 [CAD 46.4]	22.2%	-	Direct report to the IPHC (IPHC-2021-AM097-NR01)
Processing / wholesale									
BC	35.0 [CAD 46.4]	61.7%	21.6	42.4%	9.1	56.6 [CAD 75.1]	6.5%	-	Direct report to the IPHC (IPHC-2021-AM097-NR01)
Rest of Canada	~0	n.a.	n.a.	n.a.	~0	~0	~0%	-	No indication of processing outside BC
Imports, fresh	19.2	-	-	-	-	19.2	-	-	AgriService BC ²⁴
Exports, fresh	-	-	-	-	-	-	-	26.1	AgriService BC ²⁵
Import, frozen	5.0	-	-	-	-	5.0	-	-	AgriService BC ²⁶
Export, frozen	-	-	-	-	-	-	-	0.6	NOAA (2021b) ²⁷

²¹ This includes HS 0304835025: *Flatfish Halibut NSPF fillet frozen* imported from Canada to Alaska and WOC only. This is most likely an underestimate, because the Pacific halibut is also produced by Russia. The number may be also confounded by imports of Atlantic halibut from Canada, but imports to the West Coast are assumed to be dominated by Pacific halibut.

²² This includes HS 0304835005: *Flatfish halibut NSPF fillet frozen*, only export from Alaska and Washington (97.8% for this product export). This would be an underestimate in the case of secondary processing elsewhere in the United States.

²³ Calculated based on the average mark-up of fishery inputs and value added as a percent of total mark-up reported by NMFS (2018), Fisheries in the United States (FUS) report.

²⁴ Canadian trade statistics only record imports for generic fresh halibut products (HS 0302210090: *Halibut NES fresh/chilled*). Here, we report only import from Alaska, Washington and Oregon, assuming this reflects import of Pacific halibut as opposed to Atlantic halibut. However, import from the rest of the world is expected to play an increasing role in the coming years, and alternative sources for understanding Canada's Pacific halibut imports should be reviewed.

²⁵ Here, HS 03022120: *Halibut Pacific fresh/chilled* was used. US market is nearly the only export destination recorded for this product (99.994% in 2019).

²⁶ This includes HS 0303310020: *Halibut Pacific frozen*. Alaska, Washington and Oregon account for the majority (86.3% in 2019) of frozen import.

²⁷ Includes US imports of HS 0303310020: *Flatfish halibut Pacific frozen*. More generic category in the Canadian database (HS 03033100: *Halibut frozen*) reports nearly the same value and indicates that nearly all of this product (96.8% in terms of value in 2019) goes to the United States.

Imports, processed	11.0	-	-	-	-	11.0	-	-	AgriService BC ²⁸
Exports, processed	-	-	-	-	-	-	-	1.2	NOAA (2021b) ²⁹
Secondary processing	63.9	63%	40.3	28%	11.3	104.2	8.1%		FUS
Retail									
Food service	62.5	182%	113.8	70%	79.7	176.3	56.9%	-	FUS
Stores	41.7	33%	13.8	64%	8.8	55.4	6.3%	-	FUS
TOTAL VALUE ADDED ACTIVITY					140.0		100%		
CONSUMER EXPENDITURES						231.8			

Note: The table reports the contribution of commercial marine fishing to the national economy as measured by margin, value added, and sales. These measures are consistent with the Bureau of the Census definitions. n.a. – not applicable. Values in blue are from the Pacific halibut multiregional economic impact assessment (PHMEIA) model (see details in [IPHC-2022-AM098-INF04](#)). Values in grey are trade values that are derived based on the noted assumptions and may be underestimates/overestimates. All reported trade may be underestimated if Pacific halibut or some of its products are included in more generic product categories. Values in orange are calculated based on the average mark-up of fishery inputs and value added as a percent of total mark-up reported by NMFS (2018), in the Fisheries in the United States (FUS) report. These are likely underestimates for Pacific halibut, which is typically sold as a high-end product. FUS assumes reports about fifty-fifty split for edible products between food services and stores. For Pacific halibut, we assume a slightly higher share of restaurant sales (60%). The results herein are part of a continuing analysis and subject to change.

²⁸ Includes HS 0304830020: *Fillets of Pacific halibut*.

²⁹ Includes HS 0304835025: *Flatfish halibut NSFP Fillet frozen*, limited to imports by WOC from Canada. This is likely an underestimate, because it would not include any exports to other countries.